



ERGO-Flex arm hanging version

Application

The ERGO-FLEX extraction arms are designed for dust- and welding fume extraction, as well as for capturing other fine-grained dust. The pollutants are captured directly at the emission source, in a way avoiding their expansion in the process room and being inhaled by people. These arms are manufactured in a hanging or standing version. The extraction arm can work independently with a single extraction fan or in a group of local exhausts, connected to the main collecting ductwork with a central fan.

Structure

The extraction arm consists of following assemblies:

- swivel,
- hood with a shut-off damper,
- hose – sleeved onto the supporting structure of aluminium profiles,
- tension spring – to hold the extraction arm in balance.

For installing the arm on the wall or column serves a wall bracket, where additionally can be fastened a suitable fan or connection ferrule.

Adequately adjusted frictional joints (along with a spring) provide proper manoeuvring with the arm and it is easy to change its functional position. The hood can be equipped with a halogen spotlight to light up the workfield.

The ERGO-Flex extraction arm is manufactured in a nominal diameter 160 mm.

Recommended volume flow is 1000 m³/h.

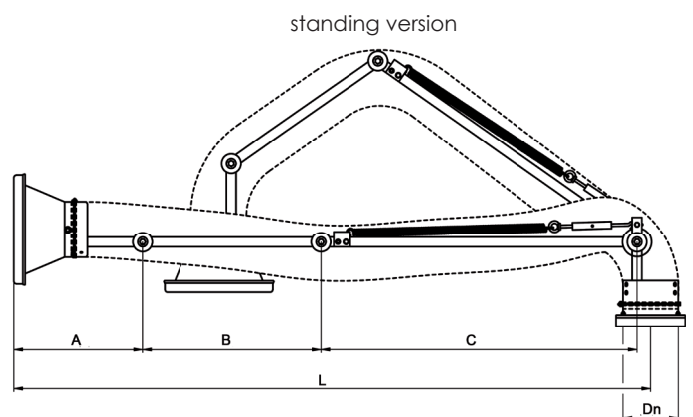
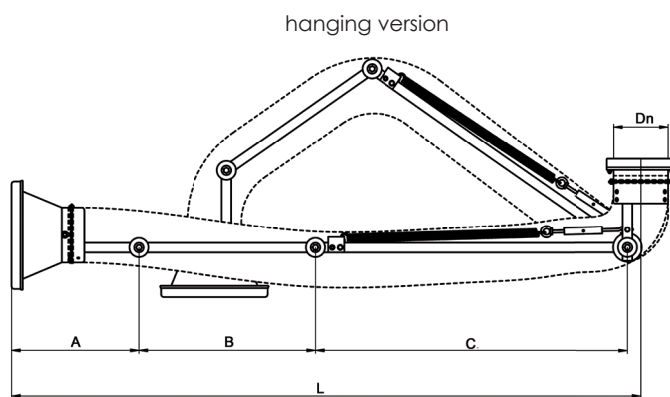

Technical data

Type	Part. No.	Dimensions					Weight [kg]
		A [mm]	B [mm]	C [mm]	L [m]	Dn [mm]	
ERGO-Flex-2	811R82	396	553	976	2	160	6
ERGO-Flex-3	811R83	396	953	1531	3	160	8
ERGO-Flex-4	811R84	396	1253	2031	4	160	9
ERGO-Flex-2-R	811R85	396	553	976	2	160	6
ERGO-Flex-3-R	811R86	396	953	1531	3	160	8
ERGO-Flex-4-R	811R87	396	1253	2031	4	160	9



Position of the arm:

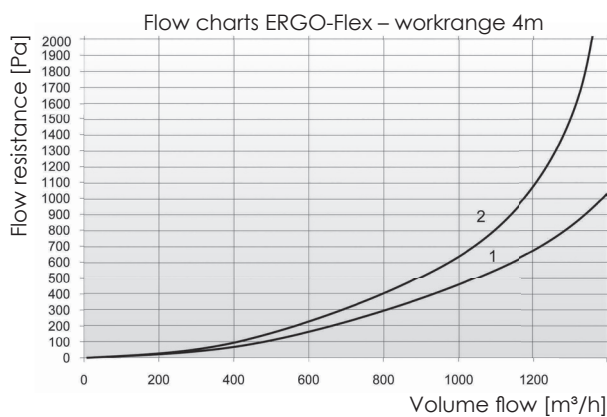
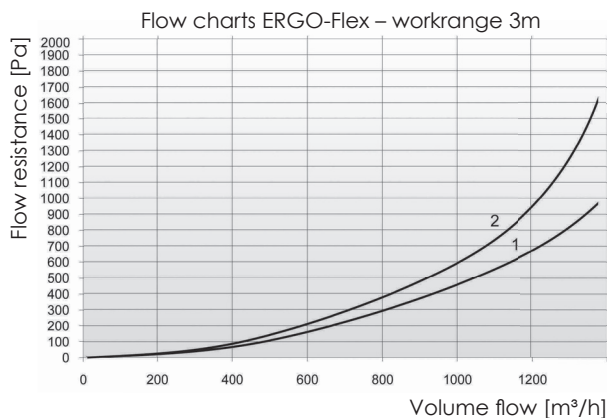
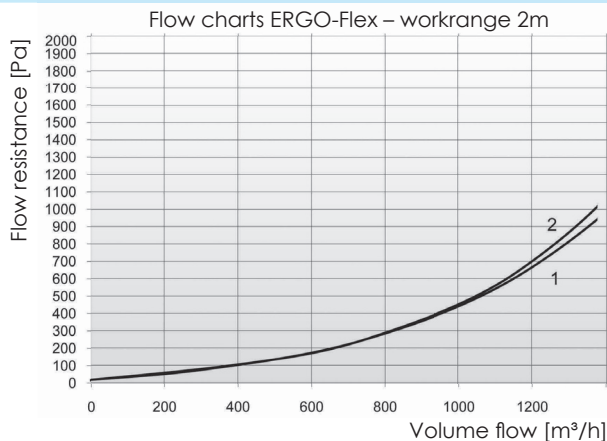
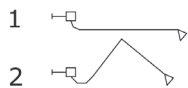

Suction hood

Sort of the hood	Material	Type	Part.No	d [mm]	D [mm]	L [mm]	Weight [kg]	Equipped with
	aluminium	LSO/Flex	810H42	173	336	226,5	1	- replaceable inlet mesh - shut-off damper
	aluminium	LLO/Flex	810H43	173	336	226,5	1,4	- replaceable inlet mesh - halogen spotlight 12V - switch - shut-off damper

Inlet mesh for the ERGO-Flex hoods

	Type	Part.No	Weight [kg]
	WOL	834Z33	0,10

Wall brackets

Sort of the bracket	Material	Type	Part.No	S [mm]	Weight [kg]	Adapted for extraction arms
	plate steel	WB-ERGO L/S	817W27	277	7	ERGO-L/Z